

TB290

Standard UK Specification - Long Dipper

Engine	
Make	Yanmar
Model	4TNV98T
Rated Output (kW)/RPM	49.6/2000
Maximum Torque (Nm)	278-302
Cylinders	4/4 cycle
Displacement (cc)	3318
Electrical System	12volt - 3.0kW

Dimensions & Weight	
Machine Weight (kg)	8384
Machine weight with hydraulic hitch, 24" bucket, full fuel tank (kg)	8800
Length (Transporting) (mm)	6660
Width (mm)	2200
Height (mm)	2565/2560
Ground Clearance (mm)	385/360
Dozer Blade (W x H) (mm)	2200 x 500
Slew Radius (mm)	1690
Dozer Blade (W x H) (mm)	2300 x 500

Swing System	
Min Front Offset Swing (mm)	2030
Tail Swing (mm)	1650

Operating Information	
Max Digging Depth (mm)	4570
Max Dump Height (mm)	5270
Max Reach at Ground Level (mm)	7290
Max Vertical Dig Depth (mm)	3805
Max Bucket Digging Force (Kn)	59.1
Max Arm Digging Force (Kn)	36.3Kn

Hydraulic System	
Set Pressure (bar)	27.5 x 1 24.0 x 1 1 3.4 x 1
Pump Type	Variable (P1) + Gear (P2 P3)
Hydraulic Pump Flow Aux port (l/min)	160 x 1 + 60.6 x 1 + 16 x 1
Aux Flow (l/min)	100

Swing System	
Boom Swing Angle (L/R)	70°/60°
Slew Speed (rpm)	10.3
Slew Motor	Axial Piston
Slew Brake	Disc

Undercarriage	
Traction Motor	Axial Piston
Traction Drive	Planetary
Traction Brake	Disc
Track Width (mm)	450
Ground Contact Length (mm)	2210/2180
Ground Pressure (kpa)	37.9/39.4
Travel Speed (K/ph)	2.6-5/2.5-4.8
Maximum Gradeability	30

Capacities	
Hydraulic System (l)	140
Fuel Tank (l)	120
Engine Lubrication (l)	10.2
Cooling System (l)	14

OPTIONS: Geo-Grip Track, Wide Steel Tracks, Takeuchi Hydraulic Breaker, Travel Alarm, Cabin Work Light, Front Guard, Arm Holding Valve, Hydraulic Quick Hitch.

Jan 2014

Takeuchi machines come with a 2 year/2000 hours warranty as standard. Warranty exceptions to 1 year; fuel injection systems, electrical components, paint work.

In accordance with our established policy of constant improvement, we reserve the right to amend these specifications at any time without notice. Photographs shown may feature non-standard equipment.

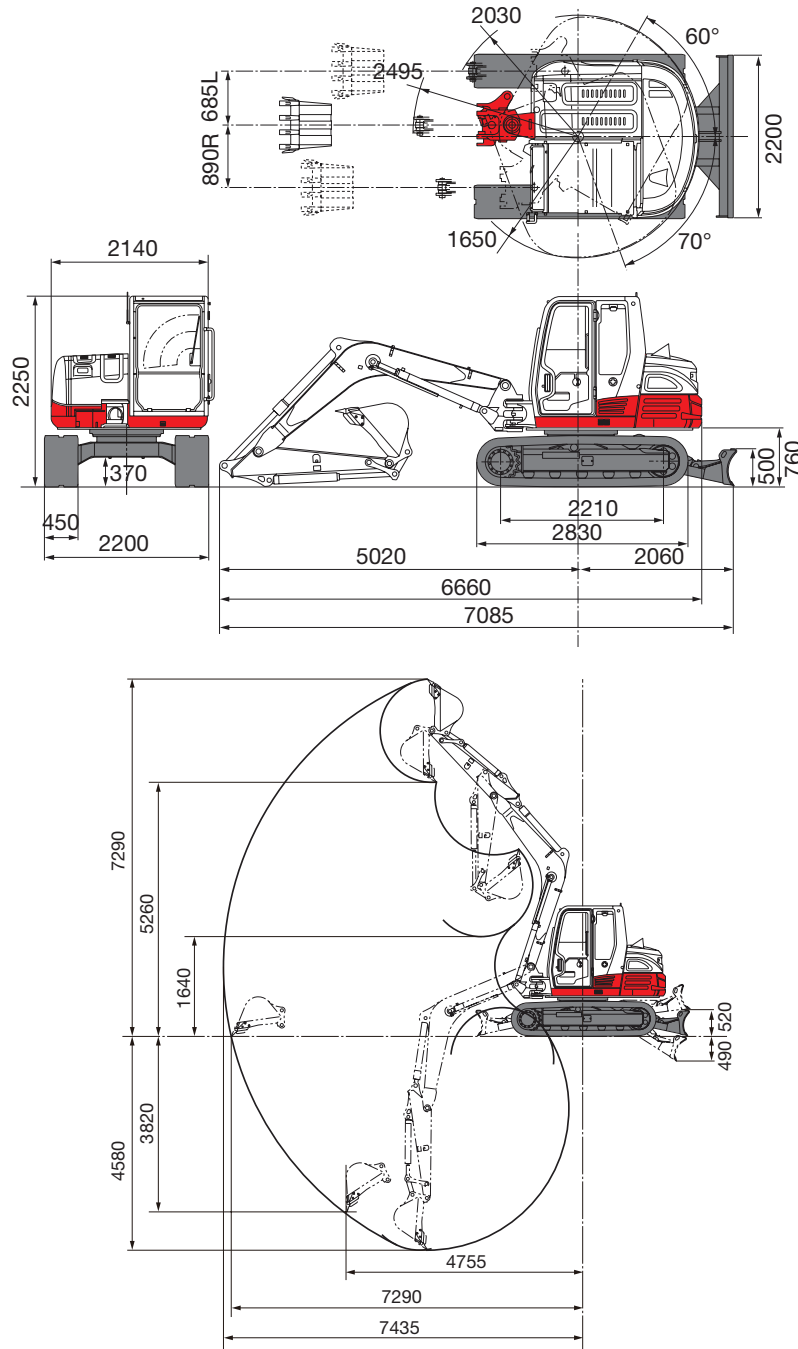

call us direct, or contact:

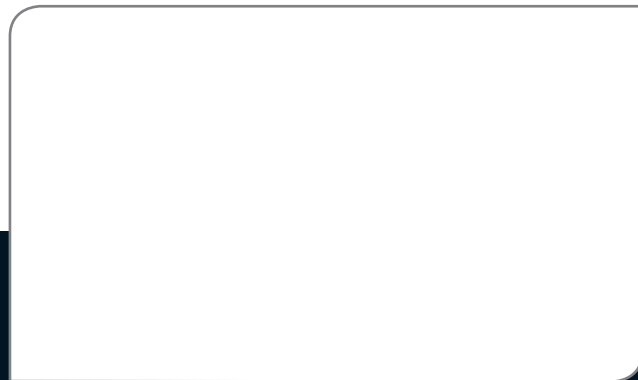

Takeuchi Mfg (UK) Ltd, Unit E2B Kingsway Business Park,
John Boyd Dunlop Drive, Rochdale, Lancashire OL16 4NG
Tel: 01706 657 722 Fax: 01706 657 744

Southern Depot at 20 Colthrop Business Park
Colthrop Lane, Thatcham, Newbury, Berks RG19 4NB
Tel: 01635 877 196 Fax: 01635 877 195

www.takeuchi-mfg.co.uk Email: sales@takeuchi-mfg.co.uk

TAKEUCHI
Japanese for reliability